

**VAN**



**NOORDENNE B.V.**

**glasgroothandel en  
glasindustrie**

Postbus 196  
Transportweg 11  
Telefoon  
Telefax

3370 AD Hardinxveld-Giessendam  
3371 MA Hardinxveld-Giessendam  
(31) 0184-675875  
(31) 0184-612418

**TNO Building and Construction Research**

Nederlandse Organisatie voor  
toegepast-natuurwetenschappelijk  
onderzoek / Netherlands Organisation  
for Applied Scientific Research



Centre for Fire Research  
Lange Kleiweg 5, Rijswijk  
P.O. Box 49  
2600 AA Delft  
The Netherlands

**TNO report**

**2003-CVB-R0009[Rev.1]**

**Fire resistance of a VETROTECH Climaplus  
Vetroflam EW 60 glazing in steel Jansen Economy  
50 frame according to NEN 6069:1997 and NEN-  
EN 1364-1**

[www.tno.nl](http://www.tno.nl)

T +31 15 284 2305  
F +31 15 284 39 55

Date June 2003

Author(s) Dr. Ir. G. van den Berg  
Ing. R.D. Scheepe

Number of pages 6  
Number of appendices 4

Sponsor Vetrotech Saint-Gobain (International) A.G.  
Stauffacherstrasse 128  
CH 3000 Bern 22  
Switzerland

Project name Fire resistance  
Project number 006.25136/01.11.11

All rights reserved.

No part of this publication may be reproduced and/or published by print, photoprint, microfilm or any other means without the previous written consent of TNO.

In case this report was drafted on instructions, the rights and obligations of contracting parties are subject to either the Standard Conditions for Research Instructions given to TNO, or the relevant agreement concluded between the contracting parties. Submitting the report for inspection to parties who have a direct interest is permitted.

© 2003 TNO

## 1 SUBJECT

Window-/frame construction consisting of a Climaplus Vetroflam EW 60 glazing in a steel Jansen Economy 50 frame.

## 2 TEST PERFORMED

Fire resistance according to NEN 6069:1997 in connection with NEN-EN 1364-1.

## 3 TESTSPONSOR

Vetrotech Saint-Gobain (International) A.G.  
Stauffacherstrasse 128  
CH 3000 Bern 22  
Switzerland

## 4 PLACE AND DATE OF TEST

### 4.1 Place of the test

The test was performed at the Centre for Fire Research of TNO Building and Construction Research in Rijswijk, The Netherlands.

### 4.2 Dates regarding the test

The supporting construction was built on November 11<sup>th</sup>, 2002.  
The window-/frame construction was assembled on November 13<sup>th</sup>, 2002.  
The test was performed on November 15<sup>th</sup>, 2002.

## 5 DATE AND NUMBER OF REPORT

TNO Report 2003-CVB-R0009[Rev.1] revised in June 2003.

## 6 CONSTRUCTION TESTED

### 6.1 General

The test was performed on a window-/frame construction, which was mounted in a testing frame with a concrete lining with internal dimensions 4000 x 3000 mm (width x height). In order to accommodate the window frame, the internal dimension of the frame was reduced to 2950 x 1150 mm (h x w) by using 150 mm blocks of cellular concrete, quality class G4.

The window was constructed from

- a steel Jansen Economy 50 frame; and
- a 25 mm thick Climaplus Vetroflam EW 60 glazing.

## 6.2 Materials

General information regarding the materials used in the construction is presented in the next sections. For more information, refer to the figure 1.

### 6.2.1 Frame

Steel Jansen Economy 50 frame, outside measurements 2900 x 1600 mm. The gross dimensions of the cross-section of the frame were 40 x 50 mm (h x w), with a rim measuring 20 mm. The steel thickness of the frame construction was 2 mm.

The frame was constructed to hold a pane with dimension 2800 x 1000 mm (h x w). Technical details of the pane are listed in section 6.2.2. For more details, see figure 1.

### 6.2.2 Glazing

The double glazing was of type Climaplust Vetrolam EW 60. The pane was build up as follows;

- Vetrolam glazing with a thickness of 6 mm (directly exposed side);
- A spacer of 14 mm;
- Vetrolam glazing with a thickness of 6 mm.

Setting blocks, type Flammi, were applied with measurements 80 x 10 mm (length x width). The thickness of the various setting blocks was chosen such to allow a covering of the windowframe around the pane between 10 and 12 mm.

Glazing beads: type Jansen 402.120Z; dimensions 20 x 20 mm; steel thickness 1 mm, see also figure 1.

### 6.2.3 Fixing materials

The window frame was attached by means of 10 steel screw plugs  $\varnothing$  10 mm., 120 mm length, on both horizontal posts and vertical posts. Positions of plugs are shown in Figure 1.

### 6.2.4 Sealant materials

The rim of the frame and one side of the glazing beads were covered with a ceramic tape, 15 x 5 mm (width x thickness).

### 6.2.5 Support construction

The construction consisted of cellular concrete:

- Mass density 650 kg/m<sup>3</sup>
- Thickness 15 cm.
- Moisture content 2.5 %

## 6.3 Assembly of the window

The assembling of the window was done as follows.

- Placement and fixation of the window frame in the support construction. The space between the window frame and the support construction was filled with Rockwool.
- Covering the rim of the frame and the glazing beads with the ceramic fibre liner.
- Setting blocks were placed in the frame.

- Placement of the glass pane in the frame. The pane was adjusted to have equal distance to the rim of the frame on either side.
- Fastening the glazing beads.

## 7 SAMPLING AND PREPARATION OF TEST SPECIMEN

|                                    |  |
|------------------------------------|--|
| Centre for Fire Research, TNO      |  |
| Building and Construction Research | Test frame and supporting construction |
| Vetrotech Saint Gobain             | Assembly of test specimen              |

## 8 MODE OF TESTING

### 8.1 Verification of test sample

During the assembly the parts and materials were verified from the supplied drawings.

### 8.2 Conditioning

In the period between assembling and testing the construction was stored in ambient conditions of temperature ( $20 \pm 5$  °C) and relative humidity ( $50 \pm 10$  %) in the testing laboratory of the Centre for Fire Research.

### 8.3 Fire test

#### 8.3.1 Conditions

The test was performed under the conditions as specified in NEN-EN 1364-1.

#### 8.3.2 Measurements

During the heating the following data were measured and registered:

- temperatures inside the furnace with 4 plate thermometers, regularly spread over the directly heated surface;
- surface temperatures on the non-directly heated side of the test sample with 10 thermocouples, the positions of the thermocouples are shown in figure 2;
- pressure inside the furnace at 2.7 m height from the floor;
- radiation outside the furnace at 1 m distance from the geometric centre of the test specimen;
- temperature and air velocity outside the furnace.

## 9 OBSERVATIONS DURING HEATING

After heating of 74 minutes the top side of the glazing came loose from the frame (failure w.r.t. integrity criterion)

For a more detailed description of the observations refer to Appendix A.

## 10 TEST RESULTS OF THE MEASUREMENTS OF THE FIRE TEST

Test results are given in graphs C1 to C3 of Appendix C.

The furnace conditions are presented in Appendix B.

## 11 SUMMARY

Table 1 summarises the most important results of this test.

Table 1: Test results

|  | Time from start of heating, during which the criterion was just fulfilled. |               |
|--|--|---------------|
| Criterion                              | NEN 6069:1997  | NEN-EN 1364-1 |
| Integrity                              | 74 minutes   | 74 minutes    |
| Thermal insulation<br>w.r.t. radiation | 67 minutes   | 67 minutes    |

Heating was terminated after 75 minutes. After a heating period of 60 minutes, the radiation measured was 13 kW/m<sup>2</sup>.

## 12 CONCLUSIONS

**The fire resistance** of the tested window construction following NEN 6069:1997 with respect to its separation function is **67 minutes**.

A classification following NEN-EN 1364-1 can formally not be given, because the classification system as described in prEN 13501-2 has not yet been finalised.

## 13 FIELD OF DIRECT APPLICATION AND CONDITIONS

The conclusion applies only to glass/window-frame constructions:

- which are in detail the same as the tested construction, and where the dimensions are not larger than tested;
- fitted in a cellular concrete wall with a thickness of at least 150 mm and a mass per unit volume of  $\geq 600 \text{ kg/m}^3$ . Other rigid walls of materials like brick or masonry are permitted provide the fire resistance of the wall is not less than that of the window construction tested.

#### 14 FIELD OF EXTENDED APPLICATION

In the series of the full scale fire tests carried out by TNO for Vetrotech there was a glazing tested which was built up as follows:

- Planilux 5mm.;
- spacer 14mm.;
- Vetroflam 6mm.

The results of this test are described in report number 2002-CvB-R06471. When the two tests are compared it is stated that both the Planilux glazing as well as the Vetroflam glazing which were faced to the exposed side collapse in the furnace after a heating period of 3 minutes.

The fire resistance is therefore secured by the Vetroflam glazing which is applied on the unexposed side. This means that the exposed glazing can be made of Planilux, Stadip, Securit and Vetroflam.



Ing. R.D. Scheepe



Ing. P.B. Reijman

SSG Climaplus Vetroflam

EW 60, 1000 x 2800 mm

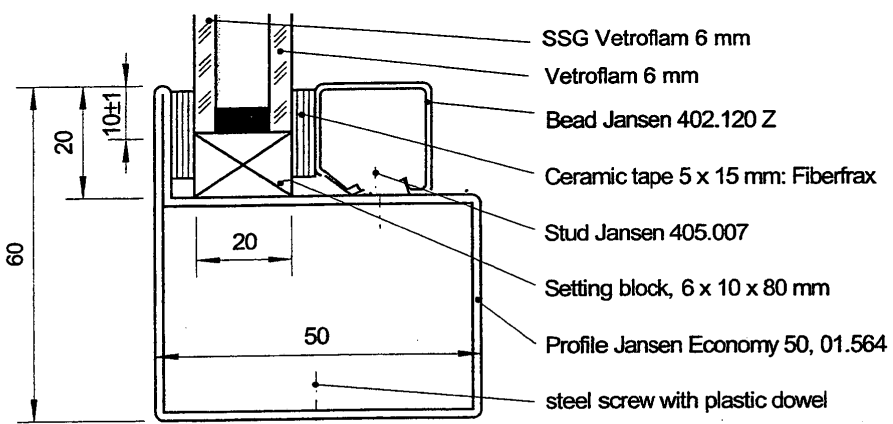
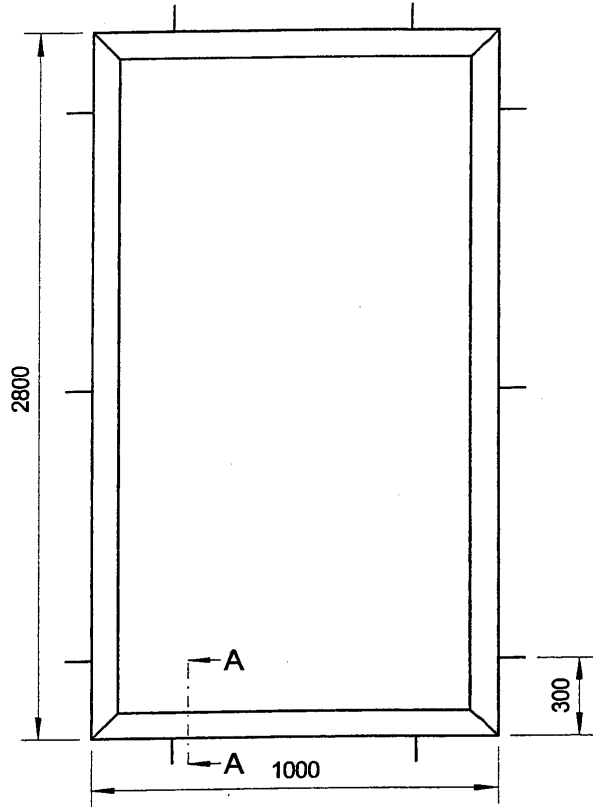

**SSG Climaplus Vetroflam Planilux EW 60, 1000 x 2800 mm**

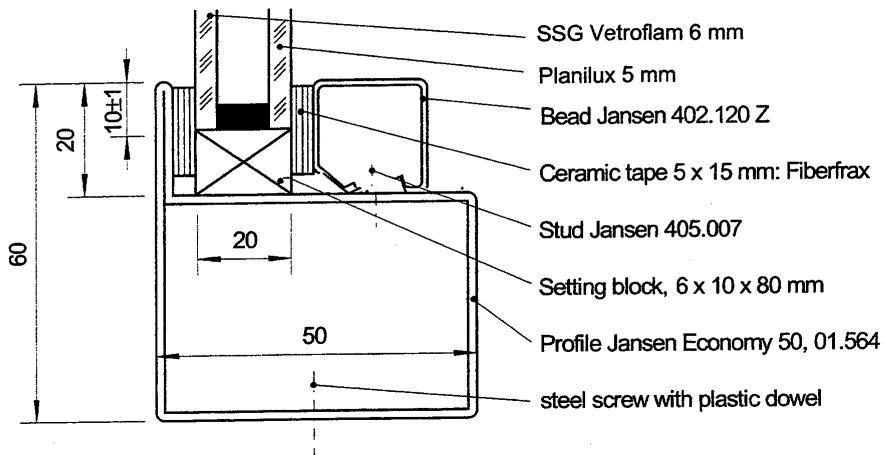

**SSG Climaplus Vetroflam Securit EW 60, 1000 x 2800 mm**

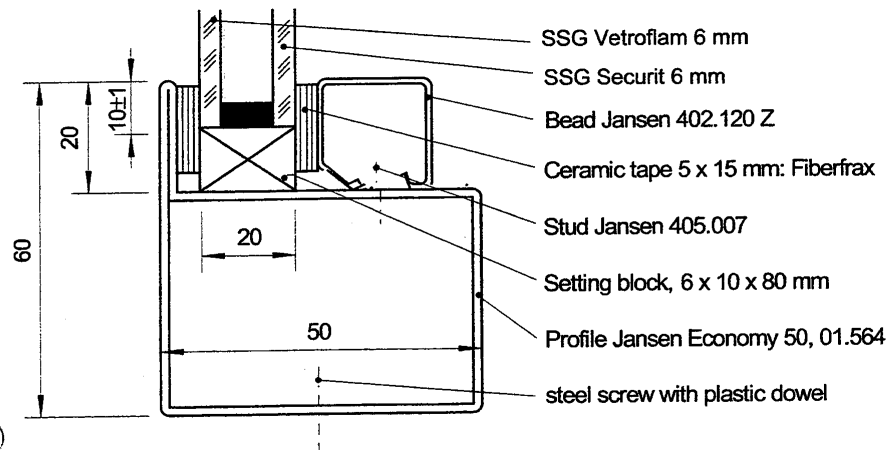

**SSG Climaplus Vetroflam Stadip EW 60, 1000 x 2800 mm**

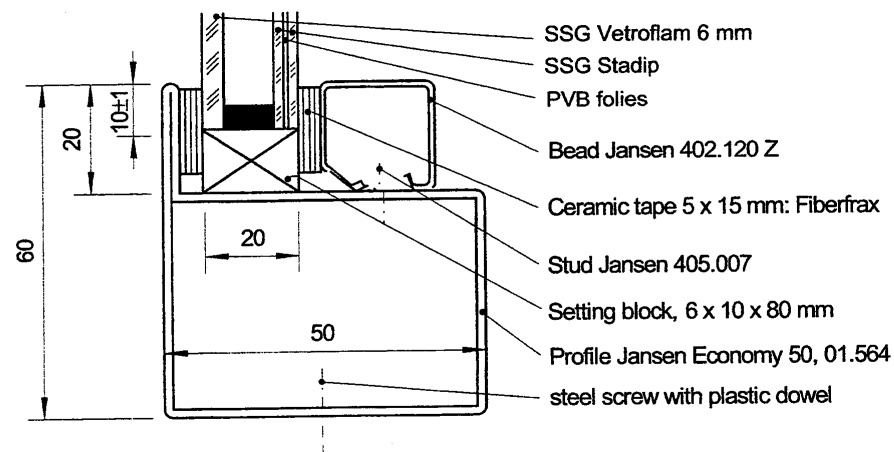

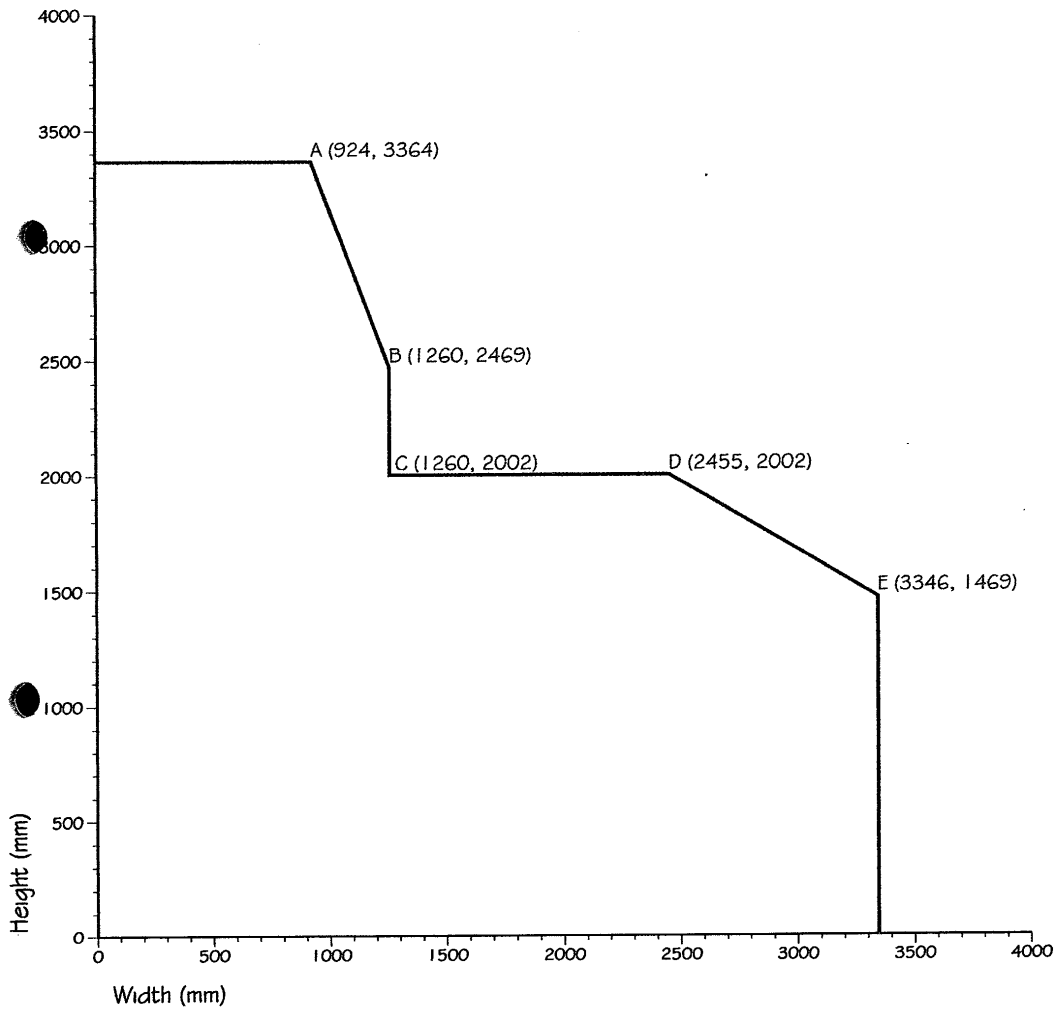

|  |  |   |
|--|--|---|
| <b>INTERNATIONAL FIRE CONSULTANTS LTD</b><br>20 Park Street, Princes Risborough, Buckinghamshire, HP27 9AH, United Kingdom<br>Tel: +44 (0) 1844 275500, Fax: +44 (0) 1844 274002, Email: ifc@intfire.com, Website: www.intfire.com |  | This drawing is Copyright©<br>Contractors must check all dimensions.<br>Any discrepancies must be reported before<br>work proceeds.<br>Only work to dimensions stated on drawing. |
| Assessment IFCA/03/02A<br>Vetrotech Saint-Gobain   | Vetroflam 60 Minute<br>Fire Resisting Steel System<br>with Clipped Beads | Job number : 663111   |
|  |  | Drawn by : CSP / Checked by : HW  |
|  |  | Not To Scale / December 2004  |

*HW*

IFCA/03/02A/09